

**SC** Show Cars  
 AUTO Automotive, Inc

## 348/409 Book of Numbers



After numerous requests from customers for numbers and other information about 348 and 409 engines we decided to compile our notes into a handbook for easy reference. All of the information contained in this book has been collected through countless hours of research involving original GM parts books, assembly manuals, other literature, and the original cars themselves. We have made every effort to ensure the accuracy of this manual, however some errors may have slipped by us. If you do spot an error please feel free to let us know. Our intention is to be of assistance to the 348-409 enthusiast in building his car. We hope that this book is helpful and if there are any ways which we may improve it please let us know.

58375 County Road 21  
New Ulm, MN 56073  
(507) 233-1958  
Fax: 800-64-SS-FAX  
Email: showcars@newulmtel.net  
Web Site: www.dr409.com

Contents

348 Block Casting Numbers.....2  
348 Head Deck Stamping Code.....2  
348 Head Casting Numbers.....3  
348 Camshaft Casting Numbers.....3  
348 Crankshaft Casting Numbers.....3  
348 Radiator Hose Numbers.....3  
348 Intake Manifold Casting Numbers.....4  
348 Exhaust Manifold Casting Numbers.....4  
348 Starter Numbers.....4  
348 Carburetor Numbers.....4  
348 Horsepower Ratings.....5  
348 Generator Numbers.....6  
348 Bell Housing Casting Numbers.....7  
348 Distributor Numbers.....7  
348 General Information.....7  
409 Block Casting Numbers.....7  
409 Head Deck Stamping Code.....8  
409 Fuel Pump Numbers.....8  
409 Carburetor Numbers.....9  
409 Exhaust Manifold Casting Numbers.....9  
409 Head Casting Numbers.....9  
409 Camshaft Casting Numbers.....10  
409 Crankshaft Casting Numbers.....10  
409 Radiator Hose Numbers.....10  
409 Intake Manifold Casting Numbers.....10  
409 Manual Trans Bell Housing Casting Numbers. .10  
409 Horsepower Ratings.....11  
409 Distributor Numbers.....11  
409 Generator Alternator Numbers.....12  
409 Starter Numbers .....12  
Production Of 409 Cars.....12  
409 General Information.....12  
Engine Number Locations.....12

348 Engine Block numbers

3732811 58 Early Without water cooled spark plugs  
3751872 58 All Have seen with & without water cooled spark plugs  
3755011 59-61 All  
3771705 59-62 Replacement Block & Truck Block  
3798962 62-65 Replacement Block & Truck Block {Has "x" On Block}  
3857655 63-65 Truck Block {Has "x" On Block}

348 Head Deck Stamping Codes

1958

F 250HP...1x4 Barrel Carburetor 3-Spe`ed Manual Transmission  
FA 280HP...3x2 Barrel Carburetors 3-Speed Manual Transmission  
FD 305HP...1x4 Barrel Carburetor Manual Transmission\*  
GB 315HP...3x2 Barrel Power Glide Manual\*  
GD 305HP...1x4 Barrel Power Glide Manual\*  
H 250HP...1X2 Barrel Turbo Glide Manual  
HA 280HP...3x2 Barrel Turbo Glide Manual

1959

F 250HP...1x4 Barrel Carburetor 3-Speed Manual Transmission  
FA 280HP...3x2 Barrel Carburetors 3-Speed Manual Transmission  
FB 315HP...3x2 Barrel.....3-Speed Manual Transmission\*  
FD 305HP...1x4 Barrel 3-Speed Manual Transmission\*  
FE 335HP...3x2 Barrel 3-Speed Manual Transmission\*  
FG 320HP...1x4 Barrel 3-Speed Manual Transmission\*  
G 250HP...1x4 Barrel Power Glide Manual  
GB 315HP...3x2 Barrel Power Glide Manual\*  
GD 305HP...1x4 Barrel Power Glide Manual\*  
H 250HP...1x4 Barrel Turbo Glide Manual  
HA.....280HP...3x2 Barrel Turbo Glide Manual

1960

F 250HP...1x4 Barrel 3 Or 4 Speed Manual Transmission  
FA 280HP...3x2 Barrel 3 Or 4 Speed Manual Transmission  
FE 335HP...3x2 Barrel 3 Or 4 Speed Manual Transmission\*  
FG 320HP...1x4 Barrel 3 Or 4 Speed Manual Transmission\*  
FH 350HP...3x2 Barrel 3 Or 4 Speed Manual Transmission\*+  
FJ 340HP...1x4 Barrel 3 Or 4 Speed Manual Transmission\*+  
G 250HP...1x4 Barrel Power Glide Manual  
GB 315HP...3x2 Barrel Power Glide Manual\*  
GD 305HP...1x4 Barrel Power Glide Manual\*  
H 250HP...1x4 Barrel Turbo Glide Manual  
HA 280HP...3x2 Barrel Turbo Glide Manual

1961

F 250HP...1x4 Barrel 3 Or 4 Speed Manual Transmission  
FA 280HP...3x2 Barrel 3 Or 4 Speed Manual Transmission  
FH 350HP...3x2 Barrel 3 Or 4 Speed Manual Transmission\*+  
FJ 340HP...1x4 Barrel 3 Or 4 Speed Manual Transmission\*+  
FL 305HP...1x4 Barrel 3 Or 4 Speed Manual Transmission+  
GD 305HP...1x4 Barrel Power Glide Manual\*  
GE 335HP...3x2 Barrel Power Glide Manual\*  
H 250HP...1x4 Barrel Turbo Glide Manual  
HA 280HP...3x2 Barrel Turbo Glide Manual

Footnotes:

\* For High Lift Camshaft

+ For Special High Performance Heads Cast 3781147

348 Head Casting Numbers

58 3732791 .....{No Water Cool Spark}  
59 3759256 .....{No Water Cool Spark}  
58-60 3758379  
60-61 3767738  
60-61 3781147 .....{High Performance Heads Larger Valves}  
?? 3815857 .....Truck  
?? 3788555 .....Truck  
62-65 3819333 .....Truck

348 Camshaft Casting Numbers

58-61 3744430 .....250 280HP

58-61 3755947 .....All Solid Lift  
 58-61 3764665 .....Police Special  
 648 Crankshaft Casting Numbers  
 58 3732692 .....Automatic and Manual Transmission  
 59-61 3741640 .....Manual  
 59-61 3741642 .....Automatic  
 58-61 3815822 .....Manual Replacement  
 59-61 3824533 .....Automatic Replacement  
 348 Connecting Rods are 6.125" long - center to center.  
 348 Radiator Hose Numbers  
 1958 3742374 .....Lower  
 1958 3750390 .....Upper 3x2  
 1958 3755917 .....Upper 1x4  
 1959 3753752 .....Lower  
 1958 3753748 .....Upper 3x2  
 1959-61 3754915 .....Upper 1x4 Without Air Conditioning  
 348 Intake Manifold Casting Numbers  
 58-59 1x4 Cast Iron with High Lift Cam....3770084  
 58-59 1x4 Cast Iron without High Lift Cam 3760436  
 61 4 Barrel Cast Iron also 409.....3767579  
 61 1x4 Cast Iron 305 hp 4 speed.....3769937  
 60-61 1x4 Cast Iron 305 hp w/ powerglide.3770083  
 59-60 1x4 Cast Iron High Performance.....3797775  
 58-61 3x2 Cast Iron 1st degree w/o bypass  
 (58) -2nd design w/ bypass.....3749948  
 58-62 1x4 Cast Iron 250HP.....3732757  
 58-59 1x4 Aluminum High Performance....3780540  
 60-61 1x4 Aluminum High Performance...3753748  
 61 1x4 Aluminum.....3767579  
 60-61 1x4 Cast Iron.....3772265  
 58-61 1x4 Cast Iron Truck.....3782757  
 62-65 1x4 Cast Iron Truck.....3844472  
 348 Exhaust Manifold Casting Numbers  
 58-61 250-280HP {and 1958 315-305HP}  
 Driver's Side.....3732793  
 Passenger's Side .....3732794  
  
 59-61 {305-315-320-340HP}  
 Driver's Side.....3767583  
 Passenger's Side .....3767584  
 Note: These Are The Same Manifold Found On 61 409  
 348 Starter Numbers  
 1958  
 All Turbo Glide.....1107688  
 Power Glide and Manual...1107687 1st Design  
 Power Glide and Manual 1107712 2nd Design For  
 All High Lift Camshaft  
 1959  
 Power Glide and Manual...1107688 All Except High Lift Camshaft  
 All Turbo Glide.....1107687  
 Power Glide and Manual...1107712 All With High Lift Camshaft  
  
 1960  
 All Turbo Glide.....1107687  
 Power Glide and Manual...1107688  
  
 1961  
 All Turbo Glide.....1107687  
 Power Glide and Manual...1107688  
 348 Carburetor Numbers  
 1958 250HP  
 Carter WCFB.....2656.....Manual Transmission  
 Carter WCFB.....2657.....Manual Transmission  
 Rochester.....7011108 Automatic Only  
 Middle .....7011952 Automatic {7012503 Manual}

Rear .....7011953

1958 Model 3x2 Cars Built After 1/15/58

Front .....7012851

Middle .....7011952 Automatic {7012503 Manual}

Rear .....7012853

1959 250HP

Carter WCFB.....2816S...Automatic

Carter WCFB.....2817S...Manual

Rochester.....7019006 Automatic Only

1959 305-320HP

Carter AFB.....2897S

1959-61 280-315HP 3x2

Rochester

Front .....7013015

Middle .....7013016 .....Automatic Without Air

.....7013026 .....Automatic With Air

.....7013020 Manual All

Rear .....7013017

1959-61 335-350HP 3x2

Rochester

Front .....7013973

Middle .....7013974

Rear .....7013975

1960-61 250HP

Carter WCFB.....3061.....Automatic

Carter WCFB.....3060.....Standard

Rochester.....7019006 Automatic Only

1960-61 305-320-340HP

Carter AFB.....3012S

1961 305-320-340HP Late

Carter AFB.....3221S

348 Horsepower Ratings

1958-61

250 HP @ 4400 RPM

One Four Barrel

9.5:1 Compression (Hydraulic Lift Camshaft)

Torque 356 @ 3600 RPM

1958-61

280 HP @ 4800 RPM

Three Two Barrel

9.5:1 Compression (Hydraulic Lift Camshaft)

Torque 355 @ 3600 RPM

1958-61

305 HP @ 5600 RPM

One Four Barrel

11:1 Compression (Solid Lift Camshaft) \*Except 61 FL Stamp Torque 350 @ 3600 RPM

1958

315 HP @ 5600 RPM (Police Special)

One Four Barrel

11:1 Compression (Solid Lift Camshaft)

Torque 356 @ 3600 RPM

1958-61  
315 HP @ 5600 RPM  
Three Two Barrel  
11:1 Compression (Solid Lift Camshaft)  
Torque 356 @ 3600 RPM

1959-60  
320 HP @ 5600 RPM  
One Four Barrel  
11.25:1 Compression (Solid Lift Camshaft)  
Torque 358 @ 3600 RPM

1959-61  
335 HP @ 5800 RPM  
Three Two Barrel  
11.25:1 Compression (Solid Lift Camshaft)  
Torque 362 @ 3600 RPM

1960-61  
340 HP @ 5800 RPM  
One Four Barrel . .  
11.25:1 Compression (Solid Lift Camshaft)  
Torque 362 @ 3600 RPM

1960-61  
350 HP @ 6000 RPM  
Three Two Barrel  
11.25:1 Compression (Solid Lift Camshaft)  
Torque 362 @ 3600 RPM

348 Generator Numbers  
58-62 All Except Power Steering Or High Lift Camshaft.....1102174  
58-62 All With High Lift Camshaft Or Power Steering.....1102268  
348 Bell Housing Casting Numbers  
1958-1ST..... 3741311.....Cast Iron GM Part # 3750809  
1958-2ND 3771733.....Cast Iron GM Part # 3755553  
1959-1961 3771733.....Cast Iron GM Part # 3755553  
1960-61 3779553 Aluminum GM Part # 3785644  
348 Distributer Numbers  
1958 ..... 1110930 .....All  
1959-60 1110948 .....305-315HP  
1959-61 1110919 .....305-315-320-335-340-350HP (Note: Dual Point)

348 Water Pump Casting Numbers  
1958 3732748.....No By Pass  
1958 3732750.....with By Pass  
1959-60 3755797  
1961 3765787

All 348 w/p are small bearing short pumps.

#### General Information

Internally Balanced

Cubic Inch.....348

Bore .....4.125

Stroke .....3.25

Firing Order.....1-8-4-3-6-5-7-2

Spark Plugs.....AC44-Standard, AC45-Hotter, AC43-Colder

Plug Gap.....035

Crankshaft Mains .....2.4977

Crankshaft Rods. ....2.199

Connecting Rod Length.....6.125  
 Head Bolts.....7/16" - 14 X 3 7/16", 16 short  
 Head Bolts.....7/16" - 14 X 4 3/16", 20 long  
 All 348 Crankshaft are Forged - has a round flywheel flange  
 Engine weight approximately 650 pounds  
 Rocker Arm ratio ... 1.75 - 1  
 Dipstick is on driver side  
 All 348s were assembled in Tonawanda  
 Push Rods  
 5/16 Exhaust = Long 9.140  
 5/16 Intake = Short 8.772  
 Fuel Pump Push Rod length = 5.750  
 All 348s are Internally Balanced

The 409 Engine  
 409 Block Casting Numbers  
 1961 3795623\*

*\*There are many questions surrounding the 61 casting numbers. First of all, the 61 casting number (the correct one) is a higher number than the '62 casting number. This is because the 409 was not scheduled to make its initial appearance until the 1962 model year. Because of increasing pressure from sources such as the Ford 390 and the Pontiac 421 as well as the change in NASCAR rules outlawing multiple carburetor set-ups, the 409 was brought out early in a down-tuned version that could be conceived as a bored and stroked 348 although the 348 water jackets were too thin to take the over-bore needed. This is all documented and factual information. The following is a theory we have developed based on those facts.*

*There were five different possibilities of casting numbers for the '61 model based on different situations.*

- 1. Casting Number 3795623 was the way that GM intended the casting number to read.*
- 2. Casting Number 3995623 was most likely a mistake. GM did not use casting numbers in the 3900000s until the '65 model year and therefore '61 engines with this number were probably the result of the wrong number being cast.*
- 3. Casting Number 3795623 with the 7 stamped in. This was probably one of the miscast engines that was caught before it went out. The incorrect 9 was ground off and the 7 stamped in to make it correct.*
- 4. Casting Number 3788086. That is, of course, the '62 casting number and is doubtful but not impossible that any of the '62s made it into the '61 automobiles.*
- 5. 3795623 all stamped into the block. We have seen this before and in most cases feel that it is probably an attempt at a counterfeit although it may be possible that GM took some 3788068s late in the model year and ground them down, and made them read 3795623.*

*We believe that most of the 61 409 blocks were cast in Dec. 1960 and that production was halted temporarily by May 1961.*

1961	3795623.....	Only 142 were cast
1962	3788068	
1963	3830814.....	Has "x" On Block
1964	3844422.....	Has "x" On Block
1965	3857656.....	Has "x" On Block Car or Truck
409 Head Deck Stamping Code		
1961		
Q	360HP...1x4 Barrel Carburetor	Manual Transmission
QA	360HP...1x4 Barrel Carburetor	Manual Transmission
1962		
QA	380HP...1x4 Barrel Carburetor	Manual Transmission
QB	409HP...2x4 Barrel Carburetors	Manual Transmission
1963		
QA	400HP...1x4 Barrel Carburetor	Manual Transmission
QB	425HP...2x4 Barrel Carburetors	Manual Transmission
QC	340HP...1x4 Barrel Carburetor	Manual Transmission
QG	340HP...1x4 Barrel Carburetor	Automatic Transmission Powerglide

QM 435HP...2x4 Barrel Carburetors Manual Transmission RPO Z-11 427CI

1964

QA 400HP...1x4 Barrel Carburetor Manual Transmission  
QB 425HP...2x4 Barrel Carburetors Manual Transmission  
QC 340HP...1x4 Barrel Carburetor Manual Transmission  
QG 340HP...1x4 Barrel Carburetor Automatic Transmission Powerglide  
QN 400HP...1x4 Barrel Carburetor Manual Transmission Transistor Ignition  
QP 425HP...2x4 Barrel Carburetors Manual Transmission Transistor Ignition  
QQ 340HP...1x4 Barrel Carburetor Manual Transmission Transistor Ignition  
QR 340HP...1x4 Barrel Carburetor Automatic Transmission Transistor Ignition Powerglide

1965

JA 400HP...1x4 Barrel Carburetor Manual Transmission  
JB 340HP...1x4 Barrel Carburetor Manual Transmission  
JC 340HP...1x4 Barrel Carburetor Manual Transmission Transistor Ignition  
JD 400HP...1x4 Barrel Carburetor Manual Transmission Transistor Ignition  
JE 340HP...1x4 Barrel Carburetor Automatic Transmission  
JF 340HP...1x4 Barrel Carburetor Automatic Transmission Transistor Ignition

409 Fuel Pump Numbers

1961 .....AC Delco.....3799  
1962 .....AC Delco.....4657  
1963 .....AC Delco.....6842  
1964 .....AC Delco.....6842  
1965 .....AC Delco.....6842

409 Carburetor Numbers

1961 360HP...Carter AFB.....3270S...  
1962 380HP...Carter AFB 3345SA  
63-65 340HP...Used Rochester 4-GC  
1963 340HP 4-GC - Standard....7020024  
1963 340HP 4-GC - Manual.....7020023  
1963 400HP...Carter AFB.....3499S...  
1964 340HP 4-GC - Manual Trans. Early. 7024123  
3499S...  
1964 340HP 4-GC - Aut. Trans. Early.....7024124

1964 340HP 4-GC - Manual Trans. Late...7024127

1964 340HP 4-GC - Aut. Trans. Late.....7024128

1964 400HP...Carter AFB.....3499s

1962-1964.....Two Four Barrel Carburetors.....

Carter AFB.....3361S...Front

Carter AFB.....3362S...Rear (After 11/18/63, 3804 Replaces Rear Carburetor For The 1964 Model Year)

1965 400HP...Carter AFB.....3783S...  
1965 340HP 4-GC - Manual.....7025123

1965 340HP 4-GC - Aut. Trans...7025124

**409 Exhaust Manifold Casting Numbers**

1961 360HP

3767584.....Passenger side

3767583.....Driver's side

1962 380HP And 409HP-Until Mid April 1962

3814682.....Passenger side

3814683.....Driver's side

1962-1964 380HP 400HP 409HP 425HP

3822926.....Passenger side

3822925.....Driver's side



1962 Late part of service package identical to 3822925  
3822924.....Passenger side  
3822923.....Driver side

1963-1964 340HP                      3788604 - Passenger side truck can be drilled for choke tube  
3814682.....Passenger side  
3814683.....Driver's side

1965 400HP And 340HP  
3855162.....Passenger side  
3855161.....Driver's side

#### 409 Head Casting Numbers

1961 360HP.....3795586 - flow rate 215 C.F.M. with 2.19/1.72 valves 230 C.F.M.  
1962 380HP 409HP.....3814690 - flow rate 260 C.F.M.  
1963 400HP 425HP.....3814690 - flow rate 260 C.F.M.  
1963 340HP.....3830817 - flow rate 215 C.F.M. with 2.19/1.72 valves 230 C.F.M.  
1963 435HP RPO Z11. 3837731 - flow rate 215 C.F.M. with 2.19/1.72 valves 230 C.F.M.  
1964 400HP 425HP.....3814690 Until November 12, 1963 - flow rate 260 C.F.M.  
1964 400HP 425HP.....3852583 After November 12, 1963 - flow rate 260 C.F.M.  
1964 340HP.....3830817 - flow rate 215 C.F.M. with 2.19/1.72 valves 230 C.F.M.  
1965 400HP.....3852583 - flow rate 260 C.F.M.  
1965 340HP.....3830817 - flow rate 215 C.F.M. with 2.19/1.72 valves 230 C.F.M.  
1962-1965 Truck. ....3819333 - flow rate 180 C.F.M. with 2.19/1.72 valves 230 C.F.M.

215 C.F.M. will support 400 H.P.  
230 C.F.M. will support 450 H.P.  
260 C.F.M. will support 525 H.P.  
300 C.F.M. will support 600 H.P.

#### 409 Camshaft Casting Numbers

1961 360HP.....3796077  
1962 380HP 409HP.....3796077 Until Mid April  
1963 400HP 425HP.....3822930 After April 1962  
1963 RPO Z-11 435HP 3837446  
1963 340HP.....3838416  
1964 400HP 425HP.....3822930 Until November 12 1963  
1964 400HP 425HP.....3837446  
1964 340HP.....3838416  
1965 400 HP.....3837446  
1965 340HP.....3838416

#### 409 Crankshaft Casting Numbers

1961 All .....3788072  
1962 All .....3795589  
1963 All Except RPO Z-11.....3829027  
1963 RPO Z-11 435HP.....3837466  
1964-1965 All.....3838416  
Other Casting Numbers we have found:.....0819, 3787072, 3824554, 3338396, 0-191561  
All Casting Numbers will interchange except the Z11 – 3837466

#### 409 Radiator Hose Numbers

1961-1964 Without Air.....GM-AU 3780334      Upper  
1963-1964 With Air.....GM-AU 3834733.....Upper  
1961-1964 All.....GM-AU 3753752.....Lower

#### 409 Intake Manifold Casting Numbers

1961 360HP...1x4.....3767579 Aluminum  
1961 360HP...1x4.....3797776 .....Aluminum (Part of service Package)  
1962 380HP...1x4.....3814678 Aluminum  
1962 409HP...2x4.....3814881 Aluminum

1962 NASCAR.....1x4.....3822983 Aluminum  
 1962 Service..1x4.....3822929 Aluminum (Part of service Package)

1963 NASCAR.....1x4.....3822983 Aluminum  
 1963 340HP...1x4.....3830831 .....Cast Iron  
 1963 340HP...4 bbl (Rochester).3794129 .....Cast Iron  
 1963 400HP...1x4.....3814678 Aluminum  
 1963 425HP...2x4.....TOP – 3814881 Aluminum  
 1963 425HP...2x4.....BOTTOM- 3837733 .....Aluminum  
 1963 435HP...2x4.....3830623 Aluminum  
 1964 340HP...1x4.....3844465 .....Cast Iron  
 1964 340HP...4 bbl (Rochester) Cast Iron.....3844464 .....Cast Iron  
 1964 400HP...1x4.....3844463 Aluminum  
 1964 425HP...2x4.....3814881 Aluminum  
 1965 340HP...1x4.....3844465 Cast Iron  
 1965 400HP...1x4.....3844463 Aluminum  
 1962-65 Truck.....1x4.....3844472 .....Cast Iron

**409 Bell Housing Casting Numbers**

1963 3779553 Aluminum.....GM Part # 3785644  
 1964 3842942 Aluminum  
 1965 3866983 Aluminum  
 1961-1965.....3899621 GM Replacement (Not Correct, But Functional)

**409 Horsepower Ratings**

1961 360 HP @ 5800 RPM Single Four Barrel  
 11.25:1 Compression (Solid Lift Camshaft)  
 Torque-409 @ 3600

1962 380 HP @ 5800 RPM Single Four Barrel  
 11:1 Compression (Solid Lift Camshaft)  
 Torque-420 @ 3200

1962 409HP @ 6000RPM Dual four Barrel  
 11-1 Compression (Solid Lift Camshaft)  
 Torque 420 @ 4000 RPM

1963-65 340 HP @ 5000 RPM Single Four Barrel  
 10:1 Compression (Hydraulic Lift Camshaft)  
 Torque-420 @ 3200

1963-65 400 HP @ 5800 RPM Single Four Barrel  
 11:1 Compression (Solid Lift Camshaft)  
 Torque-425 @ 3600

1963-64 425 HP @ 6000 RPM Dual Four Barrel  
 11:1 Compression (Solid Lift Camshaft)  
 Torque-425 @ 4200

**409 Bell Housing Casting Numbers**

1961 3779553...Aluminum.....GM Part # 3785644  
 1962 3779553...Aluminum.....GM Part # 3785644  
 1963 3779553...Aluminum.....GM Part # 3785644  
 1964 3842942...Aluminum  
 1965 3866983...Aluminum  
 1961-19653899621-GM Replacement-(Not Correct But Functional)

**409 Distributer Numbers**

1961 1110919...All  
 1962 1110919...All  
 1963 1111023...All  
 1964 1111059...With 340HP Transistor Ignition  
 1964 1111086...400HP 425HP With Transistor Ignition  
 1964 1111085...All High Performance Except Transistor Ignition

1965 1111023...All 340HP Except Transistor Ignition  
 1965 1111059...All 340HP With Transistor Ignition  
 1965 1111085...All High Performance Except Transistor Ignition  
 1965 1111086...All High Performance With Transistor Ignition

**409 Generator, Alternator Numbers**

1961-19621102268...35 Amp Generator  
 1962-19651100842...42 Amp Alternator  
 1962-19651100694...52 Amp Alternator  
 1962-19651117765...62 Amp Alternator.....All Except Transistor Ignition  
 1964-19651100697...60 Amp Alternator.....With Transistor Ignition

**409 Starter Numbers**

1961-19631107688...All High Performance  
 1963 1107286...All 340HP With Manual Transmission  
 1964-19651107342...All (1107289 Is 63 With Powerglide)

**409 Water Pump Casting Numbers**

1963 .....Z-11.....3837691 Aluminum  
 1961-1964.....3765787

3837691 - 3765787 –

This is a small bearing short water pump, it uses a 1.165 OD x 4.700 bearing. It is 5.500 long from block flange to fan. The OD of the bearing casting is 1.625 + or - .100, castings vary in size.

1964 (late) - 1965.....3850141

The 3850141 is the Big Bearing or Long Water Pump. It has a 1.5 x 4.930 bearing and is 5.875 long from block flange to fan. The OD of the bearing casting is 2.100 + or - .100, castings vary in size. The pulleys for this pump (3850141) are off set 3/8" deeper and have been very hard to find.

**Production of 409 Cars**

1961 .....00142  
 1962 .....15019  
 1963 .....16902  
 1964 .....08864  
 1965 .....02828  
 Total .....43755

**General Information**

Bore .....4.3125 Inches  
 Stroke .....3.5 Inches  
 Firing Order.....1-8-4-3-6-5-7-2  
 Head Bolts.....7/16" - 14 X 3 7/16", 16 short  
 Head Bolts.....7/16" - 14 X 4 3/16", 20 long  
 Push Rods  
     Exhaust. Long 9.140  
     Intake....Short 8.772  
 Fuel Pump Push Rod.....5.750 Long

Spark Plugs.....AC44 Standard.....AC45 Hotter.....AC43 Colder  
 Spark Plug Gap....035  
 Crank Shaft Mains.....2.4977  
 Crank Shaft Rods2.100  
 Connecting Rod Length.....6.000  
 Connecting Rod Weight.....25.025 ozs.  
 All 409 Crankshafts are Forged has a bell shape flywheel Bolt Flange  
 Engine weight approx.....650 lbs.  
 Rocker arm ratio..1.75 - 1  
 Dipstick is on passenger side  
 409s were assembled in Tonawanda New York

# Engine Number Locations

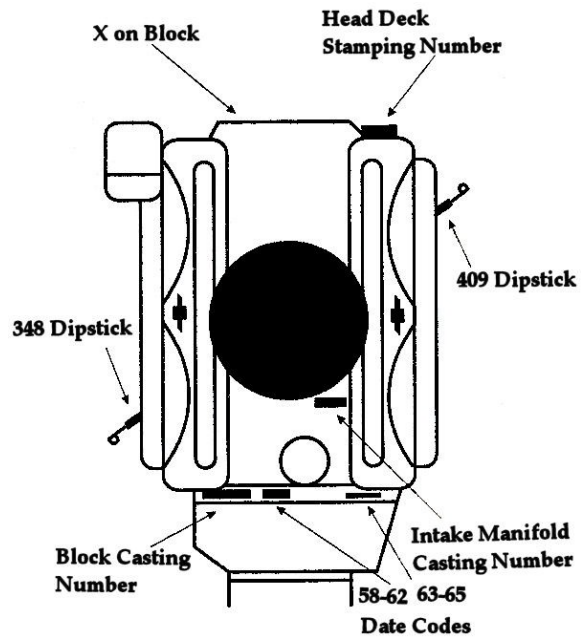

.....T.....01.....23.....QB  
Motor Assy . Plant    Month    Day    HP & Trans Code  
T    (Tonawanda, NY)